

# Proximity-Sensor Counter Installation Instruction Model: MRC-PRO

NYS DOT Approval



**SYSDYN**



**E CORP.**

**1055 Summer St. 1<sup>st</sup> Floor**

**Stamford, CT 06905**

**Tel: (203)327-3649**

**Fax: (203)325-3600**

# Contents:

<b>Introduction</b>	<b>1</b>
<b>What Components should I Have?</b>	<b>2</b>
<b>Hardware Installation</b>	<b>3</b>
Mounting the Counter	3
Mounting the Fork-Plate	3
Mounting the Sensor	5
<b>Wiring Installation</b>	<b>6</b>
Sysdyne's proximity sensor and MRC-PRO counter	6
<b>Counter Power-Up and Operation</b>	<b>7</b>
<b>System Test and Sensor Adjustment</b>	<b>8</b>
System Test: To verify proper system installation and operation.	8
Adjusting the Sensor: To ensure reliable operation.	8
<b>Troubleshooting</b>	<b>10</b>

# Introduction

Sysdyne's MRC-PRO proximity-sensor counter is our new mixing revolution counter utilizing state-of-the-art technology. It has met Standard specification and has been approved by the New York State Department of Transportation for use on concrete truck mixers.

The MRC-PRO counter is capable of tracking mixer revolutions per minute and mixer direction. The MRC-PRO counter will keep a count of the "Number of Drum Revolutions at Speeds within the Mixing Range" as well as the "Total Number of Drum Revolutions." Also, the MRC-PRO counter can display "Current barrel RPM" and "Total Batch Mix Time".

Old limit switches wear out quickly, because of the physical contact involved, and require frequent maintenance or replacement. Since the Proximity-sensor doesn't require any physical contact, no parts wear out and the sensor has a much longer lifetime. We've gotten reports of proximity-sensor systems lasting more than five years without any problems, maintenance, or parts failure. We along with our current customers stand by this technology with full confidence.

Due to its versatility the MRC-PRO can replace malfunctioning counters without complete system replacement. The MRC-PRO counter will work with old style Limit Switches as well as Proximity-Sensors of varying types. Clarification of the type of sensor is needed when placing a purchase order so that Sysdyne can preset the counters for the proper sensor.

If any problems are encounter during installation please refer to the troubleshooting section at the end of this document.



# What Components should I Have?

- Sysdyne's MRC-PRO counter
- Proximity sensor
- Installation Harness (For Counter power and Sensor/Switch connection)
- Fork plate (For use with Proximity Sensor)
- Reset Cable (Sent as needed)

Sysdyne's MRC-PRO proximity-sensor counter can be used with a proximity sensor or traditional old style limit switch. The counter box is sealed and water-resistant for protection against the elements. The Installation Harnesses attach to a plug that sends power to the counter and sends the sensor/switch signal to the counter. The metal fork-plate **is a must** for use with the proximity sensor and attaches to the drum. The metal fork-plate is made of steel for easy welding if needed and the solid base can be modified for easy mounting. The AC reset cable is used to reset the counter when a new batch enters the truck. The AC reset cable will be included if needed by the customer.

**NOTE: Sysdyne provides standard sensing Fork-Plate. Please check with Sysdyne if severe modification of the fork-plate is needed for mounting!!! Certain parts of the fork-plate need to be unchanged in order to guarantee proper and reliable operation of the MRC-PRO counter system.**

# Hardware Installation

## *Mounting the Counter*

Counter should be mounted in a location by the driver's seat convenient for the driver to see the counter's display. Make sure to tighten all mounting screws so the counter won't move around when the truck is moving.

## *Mounting the Fork-Plate*

The metal plate should be mounted on the truck's drum as close to the center axle as possible, while the sensor should be mounted on the drum's support facing the metal plate **in parallel** (See illustrations below). The plate should be positioned so the sensor will be looking at the side of the fork-plate, when the drum is spinning in the mixing direction the narrow fork-post will pass by the sensor first, then the space and then the wide fork-post. The metal plate should pass directly in front of the sensor **without** coming in contact with the sensor. See Fig. 1 below and Picture on next page for reference.

The key factors when mounting the sensing fork-plate and sensor:

1. The plastic face of the sensor **will need to be between 1/2 inch and 3/4 inches** of the surface of the fork-plate;
2. The sensor will need to be mounted **no lower than 2 inches from the bottom** of the space between the fork-posts;
3. Make sure it's at least **1 1/2 inches** from the drum surface at the forks. If the drum is too close to the metal plate then the sensor may see the drum and may not count properly;
4. **It is important to mount the metal plate in the right direction.** When the metal plate is rotating with the drum in the mixing direction, the narrow fork-post of the plate should pass the sensor first, then the wide fork-post of the plate. When the drum is rotating in the other direction, the wide fork-post of the plate will pass the sensor first, therefore the counter won't count.

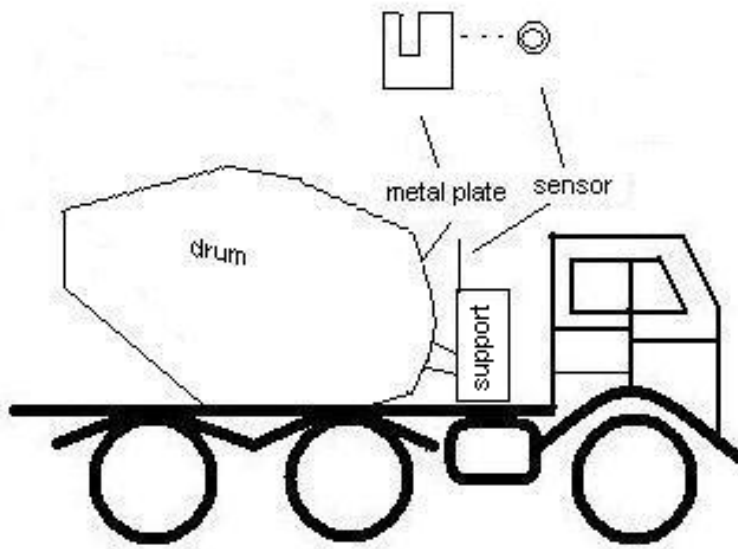

Fig. 1 Mounting sensor and metal plate (Picture Below)



## ***Mounting the Sensor***

The sensor should be mounted at the side of the drum's support to **minimize the tilt impact** when the drum is fully loaded (See Fig. 1 for drum support). **If the metal plate moves farther from or closer to the sensor when the truck is loaded then the counter could stop working or the sensor could be damaged.** The bracket must be mounted so it is movable to bring the sensor closer to or farther from the fork plate **without** moving the sensor in the bracket.

**The Sensor must be mounted in the sensor bracket so the flat plastic face of the sensor is at least  $2\frac{3}{4}$  inches out from the sensor bracket (See figure below).** The sensor can see backwards and will see its own bracket if not properly installed; this could shorten the life of the sensor. The face of the sensor should also be at least  $2\frac{1}{2}$  inches from the drum surface.

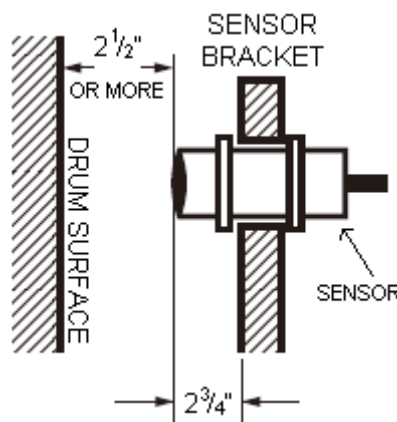

**The Sensor should be mounted so when the fork-plate is directly in front of it there is at least 2 inches between the plastic face of the sensor and the base of the gap between the fork-plate-prongs.** See Figure Below.

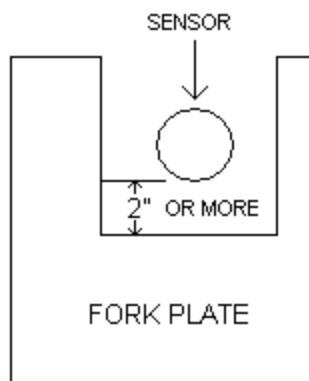

The sensor bracket will need to be moveable so the sensor's distance from the fork-plate can be adjusted from about  $\frac{1}{2}$  inch to at least 1 inch. This is how you will adjust the sensor for proper operation.

# Wiring Installation

The Installation Harness has two cables. The two-conductor cable provides power for the counter. White (+) wire and Black (-) wire from the thick cable connect to battery's positive terminal (+) and negative terminal (-) respectively. The three-conductor cable is for the sensor. Among the three wires, black is for the signal, red for positive pin, white for the ground.

## *Sysdyne's proximity sensors and MRC-PRO counter*

### 2-Wire Sensor

Fig. 3 shows wiring connections for a 2-wire sensor provided by Sysdyne. When connecting a two wires of the sensor to the counter's Black and White wires, there is no polarity difference. Red wire from the Harness is **not** used.

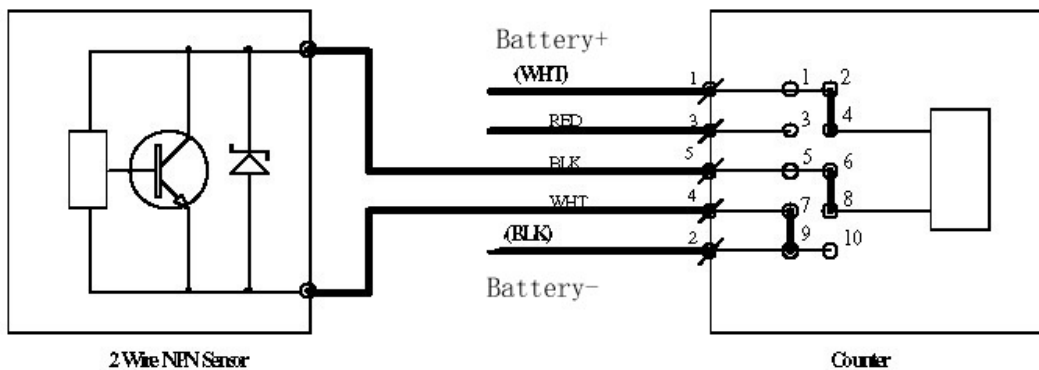

Fig.3: 2-wire-sensor Counter Connections

### 3-Wire sensor

Fig. 4 is a 3-wire sensor provided by Sysdyne. When connecting 3 wires of the sensor to the installation harness, Please make sure: Black—Black, Brown—Red, Blue—White.



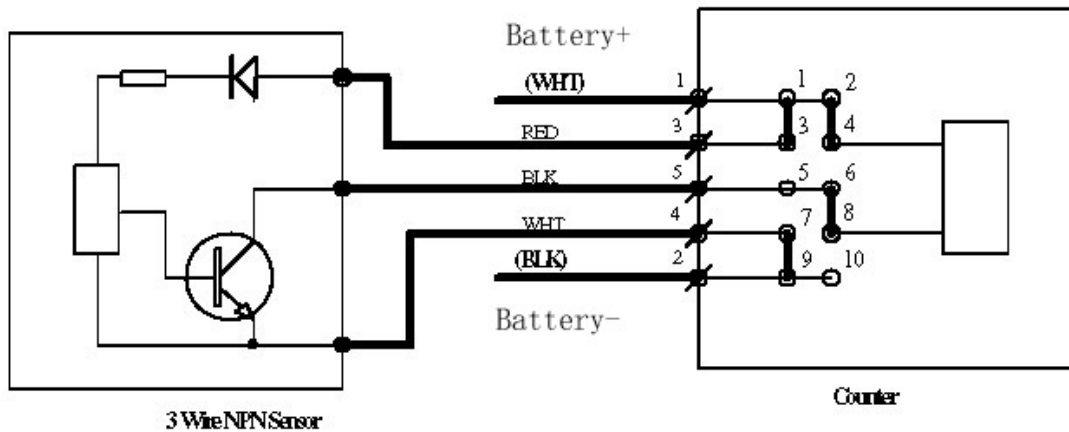

Fig.4 3-wire-sensor Counter Connection

## Counter Power-Up and Operation

Connect the power to the counter, it will display “RES” and wait for the reset signal. “RES” will only appear when the power has been disconnected and reconnected on the counter, this is a required feature in order to avoid tampering with the revolution count. Plug in the AC reset cable to the RESET connector on the counter, the display will change to “0” for mixing number and “0” for total revolution number. Remove the reset cable. The counter is ready to count. It displays two numbers, the upper number shows the mixing count and the lower one shows the total count.

Counter always needs to be reset when its power is turned off and back on.

The Red Button on the counter has two functions. Hold the button for 0.5 seconds and it will display drum’s current RPM and total mix time since the counter’s last reset; holding the button for 2.5 seconds will turn OFF/ON counter’s **display only**.

Once the system is installed properly and the sensor is adjusted the counter will only count if the drum spins in the mix direction, and will only count MIX revolutions if the drum is spinning at 6-18 RPM. If the counter counts improperly after sensor adjustment then refer to the troubleshooting section.

**(NOTE: The Red Button turns OFF/ON the display only, it does NOT turn off the counter or disable the mix count or timer, the counter will continue to count and the timer will continue to run even if the counter display is turned off by the Red Button).**

# System Test and Sensor Adjustment

## *System Test: To verify proper system installation and operation.*

Now the counter should be powered up and reset to show zeros on the display, and the sensor wired in and mounted so it can be adjusted easily from about  $\frac{1}{4}$  inch to at least 1 inch from the surface of the revolving fork-plate.

1. Rotate the Drum so the fork-plate is at least a foot away from the sensor. We want to make sure the fork-plate doesn't interfere with the first check of the counter system.
2. Now look at the back of the sensor and make sure there are no lights on in the back of the sensor (where the wire comes out).
3. Place a piece of steel (A screwdriver or wrench is fine) directly on the front plastic face of the sensor. Make sure that a Green light is on in the back of the sensor where the wire comes out. Now slowly move the steel farther away from the sensor until the green light turns Red and even farther away until no lights are on. If the lights went on as described then the sensor works.
4. Now put the piece of steel back on the sensor so at least one of the lights comes back on. While a light is on in the back of the sensor check the counter display for a Red dot in the Bottom Right corner of the display. When you pull the steel away from the sensor and the sensor lights are off the Red dot on the counter should also go off.

## *Adjusting the Sensor: To ensure reliable operation.*

**(Caution: Before starting the drum, make sure the sensor will not be hit by anything on the drum while it's spinning! If the sensor gets too close to the plate it could be struck and permanently damaged!!!)**

- Make sure all system tests in previous section pass before attempting to adjust the sensor.
- Also verify that all spacing requirements are met before attempting to adjust the sensor (See section "**Mounting the Sensor**")

Make sure both of the conditions above are met before continuing with this section. Since the system seems to be working we'll try to adjust the sensor to count properly and reliably. When the sensor is adjusted perfectly the lights on the back of the sensor should go:

START OFF → ON → OFF → ON → OFF

While the drum is spinning the fork-plate moves by the sensor one fork-post at a time (See Fig. 2). When the first fork-post is in front of the sensor the sensor light should go on, then when it sees the space in between the fork-post **no** lights should be on, then when it sees the second fork-post the light goes on again and back off once it's past. This is the result we will be looking for. When the drum is spinning slowly it's easier to see the two separate blinks.

1. First, set the space between the sensor and the fork-plate to  $\frac{1}{2}$  inch. Start drum spinning in the mixing direction at slow speed. If counter is counting then bring drum up to its highest speed. If counter still counts properly at high speed then skip to step 4. If the counter is not counting at all then continue to step 2, if it will only not count at high speeds then skip to step 3.
2. **Stop the drum.** Start by adjusting the sensor *bracket* so there is a  $\frac{1}{4}$  inch space from the sensor face and the fork-plate. Start drum spinning in the mixing direction at slow speed. If counter is counting then bring drum up to its highest speed. If counter still counts properly at high speed then skip the next step and go to step 4. If the counter is not counting at all or it will not count at high speeds then continue to step 3.
3. **Stop the drum.** Now, move the sensor *bracket* backward to bring the sensor another  $\frac{1}{8}$  inch away from the fork-plate (For example: if the space between the sensor and plate was  $\frac{1}{4}$  inch before it should now be  $\frac{5}{8}$  inch). If space between sensor face and fork-plate is now more than 1 inch then stop here and go back to the beginning of this section “**Adjusting the Sensor**”. Start drum spinning in the mixing direction at slow speed. If counter is counting then bring drum up to its highest speed. If counter still counts properly then check to make sure it will not count with the drum spinning in the opposite direction and you are done. If the counter is not counting at all or it will not count at high speeds then repeat this step.
4. Now, verify that at a high drum speed both the “Mix” and “Total” numbers count the drum revolutions. Slow the drum way down now and verify that only the “Total” number counts the drum revolutions. Finally, reverse the drum so it is spinning in the opposite of the mix direction and verify that both of the numbers are NOT counting. The counter is now working properly. Please enjoy your new Sysdyne MRC-PRO counter and if you have any problems please refer to the troubleshooting section at the end of the document.

# Troubleshooting

- Problem:** Counter doesn't display "RES" when the power is connected.

**Solution:** Check counter's power connection and cable.
- Problem:** Counter is on and resets but no lights come on when the steel is near the sensor.

**Solution:** Check the sensor connection and cable.
- Problem:** Counter resets and lights go on in test but counter doesn't count after adjustment.

**Solution:** Check that the fork-plate is mounted in the right direction (in mixing direction sensor sees narrow fork-post first). Slow down the drum speed and make sure the decimal point on the counter display blinks twice each time the fork-plate passes the sensor. Make sure all mounting dimensions for sensor are correct. If not then readjust the sensor.
- Problem:** The dot in the corner of the counter display doesn't flash every time when metal plate passes the sensor as the drum is rotating in mixing direction.

**Solution:** Might need to readjust sensor. Sensor might not be working correctly. Check sensor's connection.
- Problem:** The dot flashes, but the mixing number and total revolution number don't change at all when the drum is rotating in mixing direction.

**Solution:** If you have a proximity sensor with a fork-plate check to make sure sensor and fork-plate are mounted and adjusted properly (dot on counter display should flash twice each time fork-plate passes sensor). Check sensor wiring. Counter might be configured for a different setup than what is on your truck.
- Problem:** There is a light on in the back of the sensor even when the fork plate is more than a foot away from it.

**Solution:** First make sure that the flat plastic face of the sensor is at least 2.75 inches from the sensor bracket, if so then make sure there is no other metal within 2.75 inches of the face of the sensor.
- Problem:** After adjusting the sensor I see two Green blinks with a Red light on in between.

**Solution:** Slowly back the sensor away from the fork-plate until the counter starts counting.

8. **Problem:** After adjusting the sensor I only see one solid Green or Red blink, if I back the sensor up then the light goes out completely.

**Solution:** The sensor may be too close to the solid base of the fork-plate. Try mounting the sensor closer to the tips of the fork-posts and redo the adjustment of the sensor.

9. **Problem:** After adjusting the sensor I get two Red blinks no matter how I adjust the sensor.

**Solution:** Make sure the fork-posts pass directly in front of the sensor and parallel to the face of the sensor. Check all wiring for good solid connections. Sensor might be bad. The system will work like this but it may be unreliable, test counter thoroughly for proper operation.

10. **Problem:** Counter counts in the wrong drum direction only.

**Solution:** The fork-plate is most likely mounted backwards check in earlier sections for proper plate arrangement.

11. **Problem:** Counter counts in both directions and sometimes twice per revolution.

**Solution:** The counter is configured for the wrong type of sensor, call Sysdyne to verify and fix this.

12. **Problem:** It doesn't work and I don't know why.

**Solution:** Give us a call we'll help figure it out.      SYSDYNE 1-203-327-3649